

## TC/TD Standoff Installation Instructions

1. Drill hole in P.C. board.
2. Insert standoff in anvil and align sheet hole with shank of fastener as shown, Figure 1.
3. Squeeze the standoff and sheet between parallel punch and anvil surfaces. Use only enough pressure to seat the standoff shoulder flush with the sheet, Figure 2.

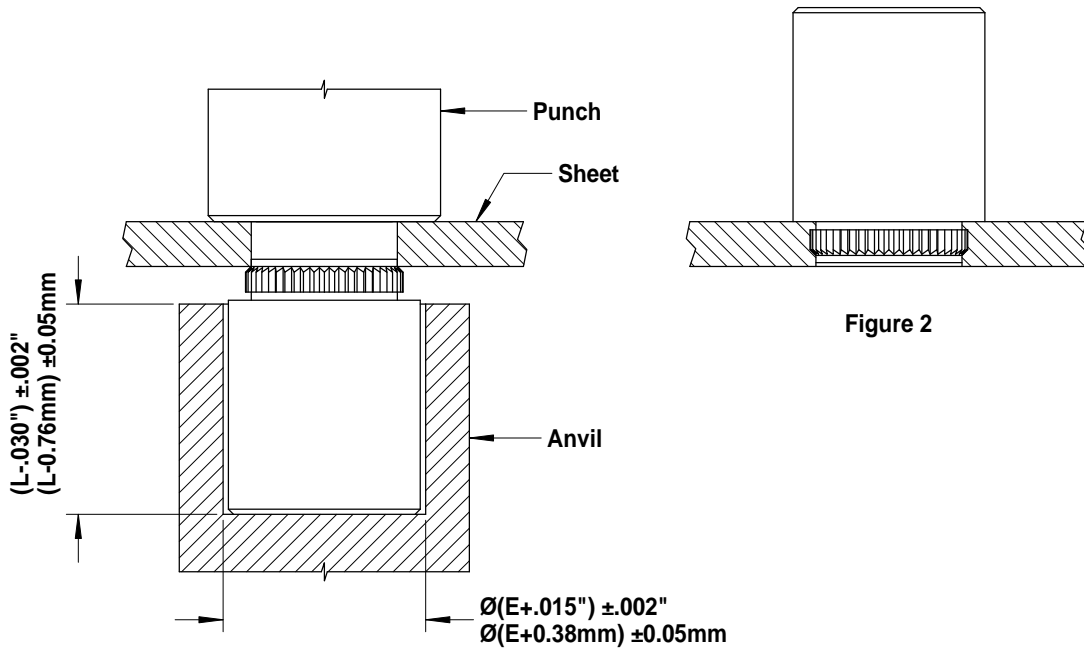

Figure 1

Figure 2

rev 01/29/08