

# Blind Thread Self-Clinching Standoffs

## FEATURES

- Precisely space mating panels and chasses.
- Self-clinching design creates a permanent installation in sheets as thin as .040" (1.00 mm).
- Blind hole prevents possible thread contamination and allows a smooth appearance on the back sides of sheets.



## PART DESCRIPTION EXAMPLE

TMST — 440 — .500 — Z

Material Code    Thread Code    Length    Finish Code

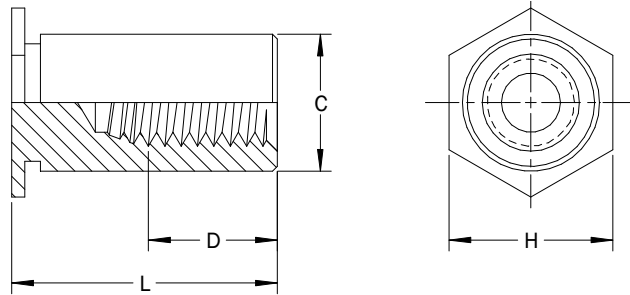

## GENERAL

All dimensions in inches

INCH	Thread	Thread Code	Sheet			C +.000 -.005	H Nominal
			Minimum Thickness	Hole Size +.003 -.000	Minimum Distance Hole Center to Edge		
4-40	440	6440	.040	.166	.23	.165	.187
			.040	.213	.27	.212	.250
6-32	632	8632	.040	.213	.27	.212	.250
			.050	.281	.31	.280	.312
8-32	832	1032	.050	.281	.31	.280	.312
10-32	1032		.050	.281	.31	.280	.312

All dimensions in millimeters

METRIC	Thread	Thread Code	Sheet			C +0.00 -0.13	H Nominal
			Minimum Thickness	Hole Size +0.08 -0.00	Minimum Distance Hole Center to Edge		
M3 x 0.5	M3	3.5M3	1.00	4.22	6.0	4.20	4.76
			1.00	5.41	6.8	5.39	6.35
M3.5 x 0.6	M3.5	4M3.5	1.00	5.41	6.8	5.39	6.35
			1.27	7.14	8.0	7.12	7.94
M4 x 0.7	M4		1.27	7.14	8.0	7.12	7.94
M5 x 0.8	M5		1.27	7.14	8.0	7.12	7.94

(1) For D dimensions see length charts on page 2.  
 (2) Custom sizes available by request.

**TM Blind Thread Self-Clinching Standoffs**

## LENGTH

All dimensions in inches

INCH	L (Length) +.002/- .005												
	.312	.375	.437	.500	.562	.625	.687	.750	.812	.875	.937	1.000	1.062
	D Min.												
	.156	.187	.250				.375						

All dimensions in millimeters

METRIC	L (Length) +0.05/-0.13									
	6	8	10	12	14	16	18	20	22	25
	D Min.									
	3.2	4.0	5.0	6.5		9.5				

(1) Custom lengths available by request.

## MATERIAL AND FINISH

Material Code	Material Description	Finish Code	Finish Description	For Use in Sheet Hardness			
				HRB 50 Max.	HRB 70 Max.	HRB 80 Max.	HRB 88 Max.
AL	Aluminum	PLN	Plain	•			
SS	300-Series Stainless Steel	P	Passivated and/or tested per ASTM A967		•		
ST	Heat Treated Carbon Steel	Z	Zinc (SC1) with Type III Clear Chromate per ASTM B633			•	
S4	Heat Treated 400-Series Stainless Steel	P	Passivated and/or tested per ASTM A967				•

## INSTALLATION

1. Prepare correct sized mounting hole in sheet. Do not deburr edges.
2. Insert standoff through hole in punch side of the sheet and into the anvil as shown.
3. Squeeze the sheet and standoff head between parallel anvil and punch surfaces. Use only enough pressure to seat the standoff head flush with the sheet. Anvils and punches should be made from hardened tool steel.
4. For installation in stainless steel, the sheet should be annealed and avoid standoff installation next to bends or other highly cold-worked areas. The hole punch diameter should be no greater than .001" (0.025 mm) over the minimum recommended mounting hole diameter and kept sharp to minimize work hardening around the hole.

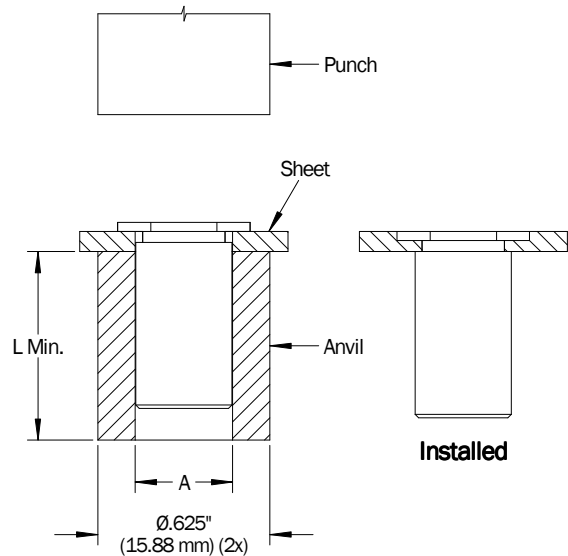

(Anvil dimensions on page 3)

TM Blind Thread Self-Clinching Standoffs

### ANVIL AND PUNCH DIMENSIONS

INCH	Standoff C Dimension	A
	.165	.172/.169
	.212	.219/.216
	.280	.287/.284

All dimensions in inches

METRIC	Standoff C Dimension	A
	4.20	4.38/4.30
	5.39	5.57/5.49
	7.12	7.30/7.22

All dimensions in millimeters

### PERFORMANCE - Material Codes AL, SS and ST

INCH	Thread Code	Standoff Material Code	Tightening Torque for Mating Screw (in-lbs) (1)	Test Sheet Material							
				.060" 5052-H34 Aluminum				.060" Cold-rolled Steel			
				Installation (lbs)	Push-out (lbs)	Torque-out (in-lbs) (2)	Pull-thru (lbs) (2)	Installation (lbs)	Push-out (lbs)	Torque-out (in-lbs) (2)	Pull-thru (lbs) (2)
				440	AL	2.9	950-1250	135-185	9.3-13	145-195	--
	SS	5.2	950-1250	135-185	9.3-13	190-260	1850-2550	190-260	16-22	225-305	
	ST	4.8	950-1250	135-185	9.3-13	240-320	1850-2550	190-260	16-22	280-380	
6440	AL	2.9	1450-1950	255-345	21-29	160-215	--	--	--	--	
	SS	5.2	1450-1950	255-345	21-29	210-285	2800-3800	355-485	30-40	260-350	
	ST	4.8	1450-1950	255-345	21-29	265-355	2800-3800	355-485	30-40	325-435	
632	AL	5.3	1450-1950	255-345	21-29	160-215	--	--	--	--	
	SS	9.6	1450-1950	255-345	21-29	210-285	2800-3800	355-485	30-40	260-350	
	ST	10.0	1450-1950	255-345	21-29	265-355	2800-3800	355-485	30-40	325-435	
8632	AL	5.3	2050-2750	340-460	38-52	210-285	--	--	--	--	
	SS	9.6	2050-2750	340-460	38-52	395-535	3400-4600	475-645	64-86	475-645	
	ST	10.0	2050-2750	340-460	38-52	495-665	3400-4600	475-645	64-86	595-805	
832	AL	10.8	2050-2750	340-460	38-52	295-400	--	--	--	--	
	SS	19.8	2050-2750	340-460	38-52	395-535	3400-4600	475-645	64-86	475-645	
	ST	16.0	2050-2750	340-460	38-52	495-665	3400-4600	475-645	64-86	595-805	
1032	AL	19.2	2050-2750	340-460	38-52	295-400	--	--	--	--	
	SS	31.7	2050-2750	340-460	38-52	395-535	3400-4600	475-645	64-86	475-645	
	ST	27.0	2050-2750	340-460	38-52	495-665	3400-4600	475-645	64-86	595-805	

- (1) Recommended mating screw tightening torque values for AL and SS standoff material codes represent published industry data for 2024-T4 aluminum and 18-8 stainless steel screws, respectively. Mating screw tightening torque values for ST standoff material codes are based on theoretical calculations using a standard torque calculation formula for low carbon steel screws. Information shown should be considered as estimates only with testing in the application to determine actual torques as values may vary depending on joint materials and fastener surfaces. PENCOM strongly encourages testing in the application to determine actual torque. Consult PENCOM literature for additional recommendations on determining tightening torques.
- (2) Torque-out and pull-thru values are for standoffs only and not the mating fasteners.
- (3) Performance data are shown in ranges and should be used for estimating purposes only as actual results may be affected by variations in installation and panel preparation equipment and procedures; and panel hardness, hole size, material and thickness. PENCOM strongly recommends testing in each application to determine actual loads.

TM Blind Thread Self-Clinching Standoffs

**PERFORMANCE - Material Codes AL, SS and ST (Continued)**

	Thread Code	Standoff Material Code	Tightening Torque for Mating Screw (N-m) (1)	Test Sheet Material							
				1.50 mm 5052-H34 Aluminum				1.50 mm Cold-rolled Steel			
				Installation (kN)	Push-out (N)	Torque-out (N-m) (2)	Pull-thru (N) (2)	Installation (kN)	Push-out (N)	Torque-out (N-m) (2)	Pull-thru (N) (2)
<b>METRIC</b>	M3	AL	0.42	4.2-5.6	605-815	1.05-1.43	635-860	--	--	--	--
		SS	1.0	4.2-5.6	605-815	1.05-1.43	845-1150	8.3-11.3	850-1150	1.83-2.47	995-1350
		ST	0.61	4.2-5.6	605-815	1.05-1.43	1060-1430	8.3-11.3	850-1150	1.83-2.47	1250-1680
	3.5M3	AL	0.42	6.5-8.7	1130-1530	2.40-3.24	700-950	--	--	--	--
		SS	1.0	6.5-8.7	1130-1530	2.40-3.24	940-1270	12.5-16.9	1580-2140	3.36-4.54	1150-1550
		ST	0.61	6.5-8.7	1130-1530	2.40-3.24	1170-1580	12.5-16.9	1580-2140	3.36-4.54	1440-1940
	M3.5	AL	0.59	6.5-8.7	1130-1530	2.40-3.24	700-950	--	--	--	--
		SS	1.1	6.5-8.7	1130-1530	2.40-3.24	940-1270	12.5-16.9	1580-2140	3.36-4.54	1150-1550
		ST	0.94	6.5-8.7	1130-1530	2.40-3.24	1170-1580	12.5-16.9	1580-2140	3.36-4.54	1440-1940
	4M3.5	AL	0.59	9.1-12.3	1510-2050	4.32-5.80	1310-1780	--	--	--	--
		SS	1.1	9.1-12.3	1510-2050	4.32-5.80	1750-2370	15.1-20.5	2120-2860	7.2-9.7	2110-2860
		ST	0.94	9.1-12.3	1510-2050	4.32-5.80	2190-2960	15.1-20.5	2120-2860	7.2-9.7	2640-3580
	M4	AL	1.18	9.1-12.3	1510-2050	4.32-5.80	1310-1780	--	--	--	--
		SS	2.6	9.1-12.3	1510-2050	4.32-5.80	1750-2370	15.1-20.5	2120-2860	7.2-9.7	2110-2860
		ST	1.36	9.1-12.3	1510-2050	4.32-5.80	2190-2960	15.1-20.5	2120-2860	7.2-9.7	2640-3580
	M5	AL	2.37	9.1-12.3	1510-2050	4.32-5.80	1310-1780	--	--	--	--
		SS	5.1	9.1-12.3	1510-2050	4.32-5.80	1750-2370	15.1-20.5	2120-2860	7.2-9.7	2110-2860
		ST	2.71	9.1-12.3	1510-2050	4.32-5.80	2190-2960	15.1-20.5	2120-2860	7.2-9.7	2640-3580

- (1) Recommended mating screw tightening torque values for AL and SS standoff material codes represent published industry data for 2024-T4 aluminum and 18-8 stainless steel screws, respectively. Mating screw tightening torque values for ST standoff material codes are based on theoretical calculations using a standard torque calculation formula for low carbon steel screws. Information shown should be considered as estimates only with testing in the application to determine actual torques as values may vary depending on joint materials and fastener surfaces. PENCOM strongly encourages testing in the application to determine actual torque. Consult PENCOM literature for additional recommendations on determining tightening torques.
- (2) Torque-out and pull-thru values are for standoffs only and not the mating fasteners.
- (3) Performance data are shown in ranges and should be used for estimating purposes only as actual results may be affected by variations in installation and panel preparation equipment and procedures; and panel hardness, hole size, material and thickness. PENCOM strongly recommends testing in each application to determine actual loads.

**TM Blind Thread Self-Clinching Standoffs**

**PERFORMANCE - Material Code S4**

INCH	Thread Code	Standoff Material Code	Tightening Torque for Mating Screw (in-lbs) (1)	Test Sheet Material			
				.050" 300-Series Stainless Steel			
				Installation (lbs)	Push-out (lbs)	Torque-out (in-lbs) (2)	Pull-thru (lbs) (2)
	440	S4	5.2	4700-6300	285-385	14-20	510-690
	6440	S4	5.2	8100-10950	550-745	26-35	580-780
	632	S4	9.6	8100-10950	550-745	26-35	580-780
	8632	S4	9.6	8950-12100	765-1040	60-82	1210-1640
	832	S4	19.8	8950-12100	765-1040	60-82	1210-1640
	1032	S4	31.7	8950-12100	765-1040	60-82	1210-1640

METRIC	Thread Code	Standoff Material Code	Tightening Torque for Mating Screw (N-m) (1)	Test Sheet Material			
				1.30 mm 300-Series Stainless Steel			
				Installation (kN)	Push-out (N)	Torque-out (N-m) (2)	Pull-thru (N) (2)
	M3	S4	1.0	20.8-28.2	1270-1720	2.01-2.71	2250-3050
	3.5M3	S4	1.0	36.0-48.6	2450-3310	2.60-3.52	2570-3480
	M3.5	S4	1.1	36.0-48.6	2450-3310	2.60-3.52	2570-3480
	4M3.5	S4	1.1	39.7-53.7	3400-4600	7.6-10	5390-7290
	M4	S4	2.6	39.7-53.7	3400-4600	7.6-10	5390-7290
	M5	S4	5.1	39.7-53.7	3400-4600	7.6-10	5390-7290

- (1) Recommended mating screw tightening torque values shown represent published industry data for 18-8 stainless steel screws. Information shown should be considered as estimates only with testing in the application to determine actual torques. Consult PENCOM technical literature for additional recommendations on determining tightening torques.
- (2) Torque-out and pull-thru values are for standoffs only and not the mating fasteners.
- (3) Performance data are shown in ranges and should be used for estimating purposes only as actual results may be affected by variations in installation and panel preparation equipment and procedures; and panel hardness, hole size, material and thickness. PENCOM strongly recommends testing in each application to determine actual loads.

**TM Blind Thread Self-Clinching Standoffs**