



DIMENSIONS:

Thread	A Head Dia. +0.020 -0.000	B Head Height -0.015	C Length ±0.015	D Thread Length ±0.010
4-40	3/8	3/16	5/8	5/16
			11/16	3/8
			3/4	7/16
6-32	3/8	3/16	11/16	3/8
			3/4	7/16
			13/16	1/2
8-32	7/16	3/16	11/16	3/8
			13/16	1/2
			15/16	5/8
10-32	7/16	3/16	11/16	3/8
			13/16	1/2
			15/16	5/8
1/4-20	1/2	1/4	3/4	3/8
			7/8	1/2
			1	5/8
			1-1/8	3/4

Material Code	Description	Finish	Description
AL	Aluminum	PLN	Plain
BR	Brass	TIN	Tin
SS	Stainless Steel	P	Passivate
STL	Steel	Z	Zinc

Drive		Description
	PH	Cross Recess
	SL	Slotted

*Other threads, materials and finishes available upon request.

PART DESCRIPTION EXAMPLE:

4 - 40 x 5 / 16 PH - THUMB - WA - SC - STL - Z

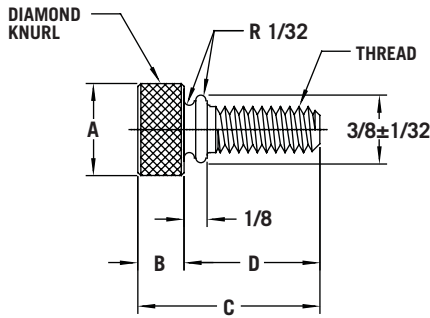

THREAD DRIVE SERIES MATERIAL FINISH



DIMENSIONS:

Thread	A Head Dia. +0.5 -0.0	B Head Height ±0.5	C Length ±0.5	D Thread Length ±0.5
M3 x 0.5	10	5	16	8
			17	9
			19	11
M3.5 x 0.6	10	5	17	9
			19	11
			21	13
M4 x 0.7	11	5	17	9
			21	13
			24	16
M5 x 0.8	11	5	17	9
			21	13
			24	16
M6 x 1	13	6	18	9
			22	13
			25	16
			28	19

Material Code	Description	Finish	Description
AL	Aluminum	PLN	Plain
BR	Brass	TIN	Tin
SS	Stainless Steel	P	Passivate
STL	Steel	Z	Zinc

Drive	Description	
	PH	Cross Recess
	SL	Slotted

*Other threads, materials and finishes available upon request.

PART DESCRIPTION EXAMPLE:

M 3 x 8 P H - T H U M B - W A - S C - S T L - Z

THREAD DRIVE SERIES MATERIAL FINISH