

TG - Standoff

Broaching, Spring-Top

Inch

Sample Part Number

TGST - .250 - Z

Series/ Length Finish
Material

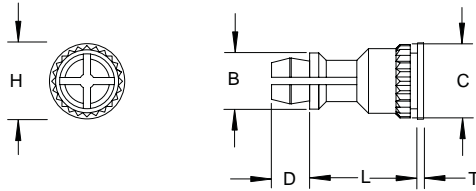

B ±.005	C ±.003	D ±.005	H ±.005	T ±.005
.188	.226	.141	.250	.020

Custom sizes available.

(L) Length ±.005									
.250	.312	.375	.437	.500	.562	.625	.750	.875	1.00

Material	Description	Finish	Description
ST	Carbon Steel	Z	Zinc Clear
SS	300 Series Stainless Steel	P	Passivate
S4	400 Series Stainless Steel	P	Passivate
BR	Brass	TIN	Tin

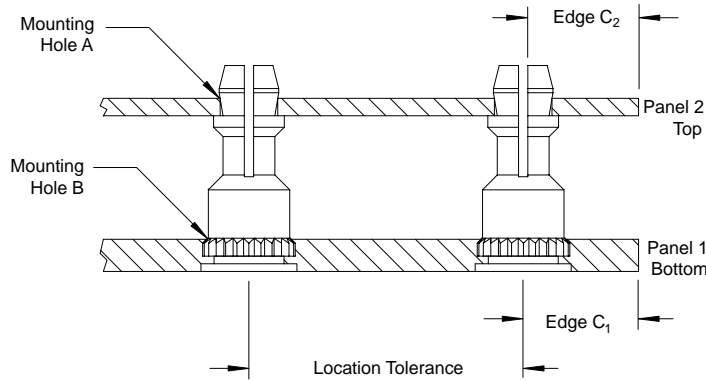

Panel 1						Panel 2				
Bottom Mounting Hole B +.003/- .000	Panel Material	Hardness MAX	Thickness MIN	Edge Distance C ₁ MIN	Location Tolerance MAX	Top Mounting Hole A +.003/- .000	Panel Material	Hardness MAX	Thickness Range	Edge Distance C ₂ MIN
.213	PC Board	HRB 65	.050	.220	±.005	.156	PC Board or Metal	No Limit	.040 - .070	.100

TG - Standoff

Broaching, Spring-Top
Metric

Sample Part Number

TGST - 12 - Z

Series/ Length Finish

Material

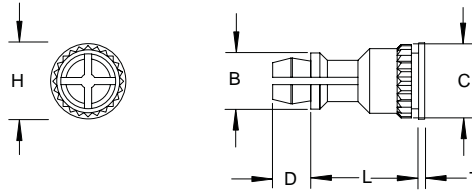

B ±0.13	C ±0.08	D ±0.13	H ±0.13	T ±0.13
4.78	5.74	3.58	6.35	0.51

Custom sizes available.

(L) Length (mm) ±0.13									
8	10	12	14	16	18	20	22	25	

Material	Description	Finish	Description
ST	Carbon Steel	Z	Zinc Clear
SS	300 Series Stainless Steel	P	Passivate
S4	400 Series Stainless Steel	P	Passivate
BR	Brass	TIN	Tin

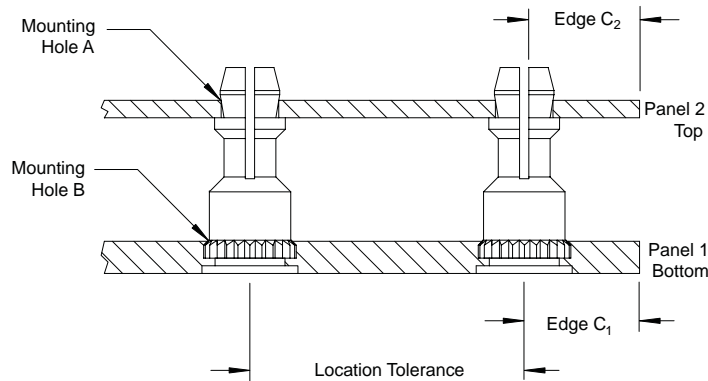

Panel 1						Panel 2				
Bottom Mounting Hole B +0.08	Panel Material	Hardness MAX	Thickness MIN	Edge Distance C ₁ MIN	Location Tolerance MAX	Top Mounting Hole A +0.08	Panel Material	Hardness MAX	Thickness Range	Edge Distance C ₂ MIN
5.41	PC Board	HRB 65	1.27	5.59	±0.13	4	PC Board or Metal	No Limit	1-1.8	2.54

All Dimensions are in Metric