

TJ - Standoff

Self-Clinching, Key-Loc
Inch

Sample Part Number

TJST - .250 - Z

Series/ Length Finish
Material

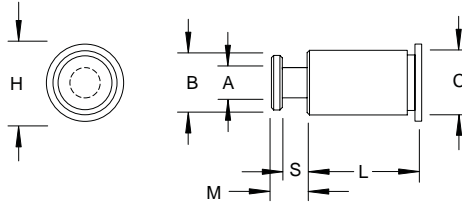

A ±.003	B ±.003	C MAX	S ±.003	M MAX	H NOM
.099	.177	.212	.068	.108	.250

Custom sizes available.

(L) Length ±.005										
.188	.250	.312	.375	.437	.500	.562	.625	.750	.875	1.00

Material	Description	Finish	Description
ST	Carbon Steel	Z	Zinc Clear
SS	300 Series Stainless Steel	P	Passivate
S4	400 Series Stainless Steel	P	Passivate
AL	Aluminum	PLN	Plain

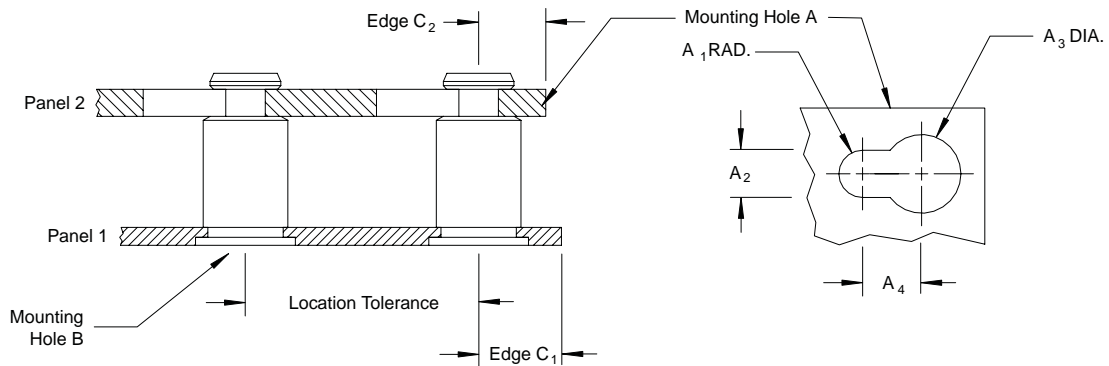

Panel 1					Panel 2						
Bottom Mounting Hole B +.003/- .000	Hardness MAX	Thickness MIN	Edge Distance C ₁ MIN	Location Tolerance MAX	Top Mounting Hole A				Material	Thickness Range	Edge Distance C ₂ MINZ
					A ₁ NOM	A ₂ ±.003	A ₃ ±.003	A ₄ MIN			
.213	HRB 70	.040	.260	±.005	.059	.118	.197	.148	PC Board or Metal	.057 - .064	.160

All Dimensions are in Inches

TJ - Standoff

Self-Clinching, Key-Loc
Metric

Sample Part Number

TJST - 10 - Z

Series/ Length Finish

Material

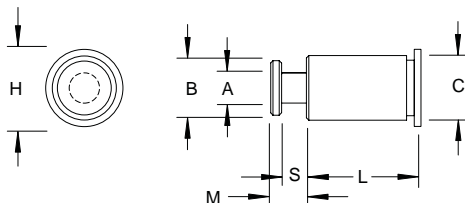

A ±0.08	B ±0.08	C MAX	S ±0.08	M MAX	H NOM
2.5	4.5	5.38	1.72	2.75	6.35

Custom sizes available.

(L) Length (mm) ±0.13									
6	8	10	12	14	16	18	20	22	25

Material	Description	Finish	Description
ST	Carbon Steel	Z	Zinc Clear
SS	300 Series Stainless Steel	P	Passivate
S4	400 Series Stainless Steel	P	Passivate
AL	Aluminum	PLN	Plain

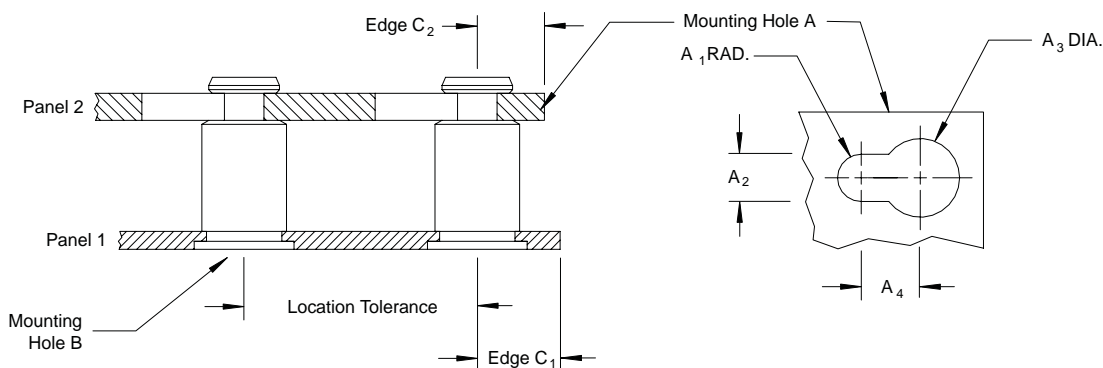

Panel 1					Panel 2						
Bottom Mounting Hole B +0.08	Hardness MAX	Thickness MIN	Edge Distance C ₁ MIN	Location Tolerance MAX	Top Mounting Hole A				Material	Thickness Range	Edge Distance C ₂ MIN
					A ₁ NOM	A ₂ ±0.08	A ₃ ±0.08	A ₄ MIN			
5.4	HRB 70	1	6.6	±0.13	1.5	3	5	3.75	PC Board or Metal	1.45 - 1.62	4.1

All Dimensions are in Metric