



Self-Clinching Floating Nuts

FEATURES

- Internal floating nut feature allows up to .030" (0.76mm) lateral adjustment to compensate for misalignment with mating fastener.
- Permanent installation in aluminum, carbon steel and stainless steel sheets.
- Self-locking version provides uniformity of locking torque equivalent to NASM25027 specifications. See the Pencom website technical reference *Locking Fastener Conformance to NASM25027* for complete information.
- Choice of RoHS-compliant materials and finishes.



PART DESCRIPTION EXAMPLE

NASS	—	832	—	.038	—	P
Series Code		Material Code		Thread Code		Shank Length
						Finish Code



The double dart design is a registered Pencom trademark

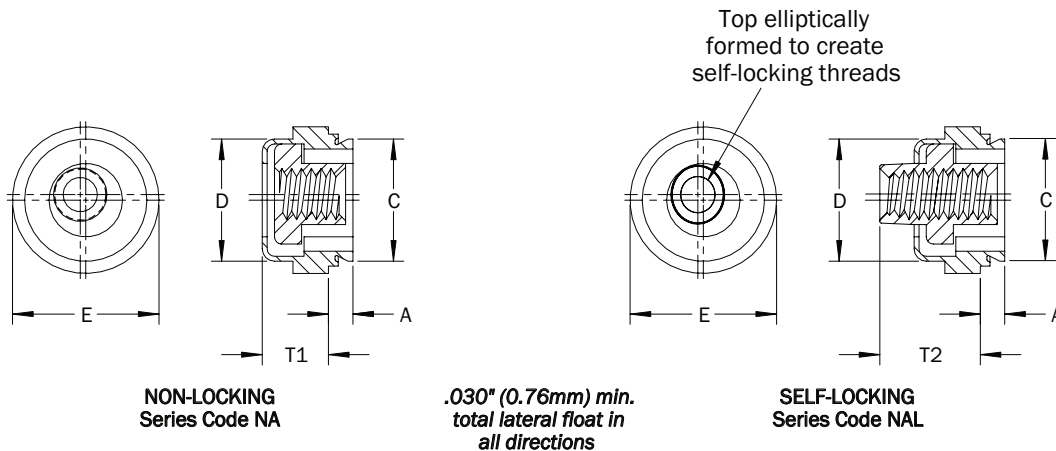

NA/NAL Self-Clinching Floating Nuts

GENERAL

All dimensions in inches

INCH	Thread ¹	Thread Code	Sheet			A Shank Length Max.	C Max.	D Max.	E ±.015	T1 Max.	T2 Max.
			Minimum Thickness	Hole Size +.003 -.000	Minimum Distance Hole Center to Edge						
2-56 ²	256		.038	.290	.30	.038	.289	.290	.360	.130	.190
			.054			.054					
4-40	440		.038	.290	.30	.038	.289	.290	.360	.130	.190
			.054			.054					
6-32	632		.038	.328	.32	.038	.327	.335	.390	.130	.200
			.054			.054					
8-32	832		.038	.368	.34	.038	.367	.365	.440	.130	.210
			.054			.054					
10-24	1024		.038	.406	.36	.038	.405	.405	.470	.170	.270
			.054			.054					
10-32	1032		.038	.406	.36	.038	.405	.405	.470	.170	.270
			.054			.054					
1/4-20	2520		.054	.515	.42	.054	.514	.510	.600	.210	.310
1/4-28	2528		.054	.515	.42	.054	.514	.510	.600	.210	.310

(1) NA and NAL-series internal threads comply with ANSI B1.1 2B and 3B thread specifications, respectively.

(2) NAL not available with 2-56 threads.

All dimensions in millimeters

METRIC	Thread ¹	Thread Code	Sheet			A Shank Length Max.	C Max.	D Max.	E ±0.38	T1 Max.	T2 Max.
			Minimum Thickness	Hole Size +0.08 -0.00	Minimum Distance Hole Center to Edge						
M2 x 0.4 ²	M2		0.97	7.37	7.62	0.97	7.35	7.37	9.14	3.31	4.83
			1.38			1.38					
M2.5 x 0.45 ²	M2.5		0.97	7.37	7.62	0.97	7.35	7.37	9.14	3.31	4.83
			1.38			1.38					
M3 x 0.5	M3		0.97	7.37	7.62	0.97	7.35	7.37	9.14	3.31	4.83
			1.38			1.38					
M3.5 x 0.6	M3.5		0.97	8.33	8.13	0.97	8.31	8.51	9.91	3.31	5.10
			1.38			1.38					
M4 x 0.7	M4		0.97	9.35	8.64	0.97	9.33	9.28	11.18	3.31	5.34
			1.38			1.38					
M5 x 0.8	M5		0.97	10.31	9.14	0.97	10.29	10.29	11.94	4.32	6.86
			1.38			1.38					
M6 x 1.0	M6		1.38	13.08	10.67	1.38	13.06	12.96	15.24	5.34	7.88

(1) NA and NAL-series internal threads comply with ASME B1.13M,6H thread specifications.

(2) NAL not available with M2 or M2.5 threads.

NA/NAL Self-Clinching Floating Nuts

MATERIAL & FINISH

Material Code	Finish Code	Retainer		Nut		For Use in Sheet Hardness	
		Material Description	Finish Description	Material Description	Finish Description	HRB 70 Max.	HRB 88 Max.
NA Non-locking							
ST	Z	Heat-treated Carbon Steel	Zinc (SC1) with Type III Clear Chromate per ASTM B 633	Carbon Steel	Zinc (SC1) with Type III Clear Chromate per ASTM B 633	•	
SS	P	300-Series Stainless Steel	Passivate and/or test per ASTM A 967	300-Series Stainless Steel	Passivate and/or test per ASTM A 967	•	
S4 ¹	P	400-Series Stainless Steel	Passivate and/or test per ASTM A 967	300-Series Stainless Steel	Passivate and/or test per ASTM A 967		•
NAL Locking							
ST	DF	Heat-treated Carbon Steel	Zinc (SC1) with Type III Clear Chromate per ASTM B 633	300-Series Stainless Steel	Black Dry-film Lubricant	•	
SS	DF	300-Series Stainless Steel	Passivate and/or test per ASTM A 967	300-Series Stainless Steel	Black Dry-film Lubricant	•	
S4 ¹	DF	400-Series Stainless Steel	Passivate and/or test per ASTM A 967	300-Series Stainless Steel	Black Dry-film Lubricant		•

(1) Not available in 2-56, 4-40, 6-32, 8-32, 10-24 and 10-32 thread sizes with .054" shank length; M2, M2.5, M3, M4 and M5 thread sizes with 1.38mm shank length; and 1/4-20, 1/4-28 and M6 thread sizes.

INSTALLATION

1. Punch or drill hole in sheet. Do not deburr edges.
2. Insert fastener in recessed anvil and locate sheet hole over the retainer shank.
3. Squeeze the fastener and sheet between parallel punch and anvil surfaces.
Use only enough pressure to seat the retainer shoulder flush with the sheet.
Punch and anvil should be made from hardened steel.

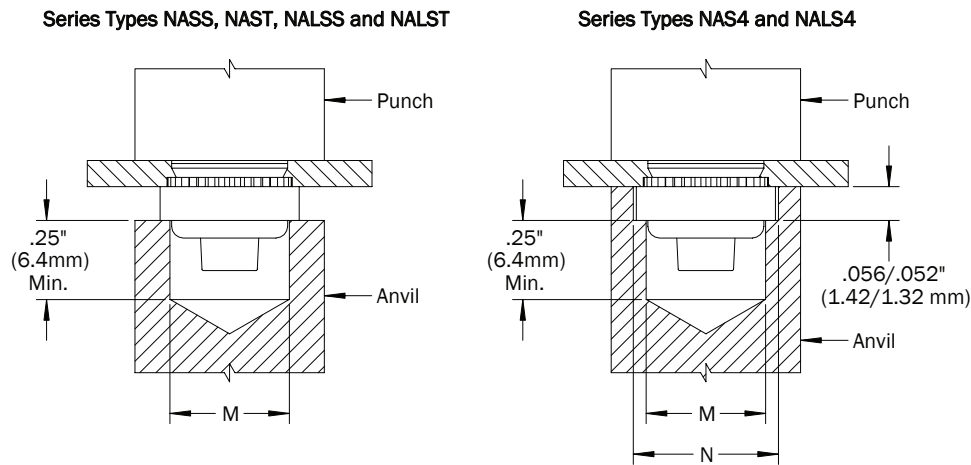

(Type NAL Shown Installed in Sheet)

NA/NAL Self-Clinching Floating Nuts

ANVIL DIMENSIONS

INCH	Thread Code	M +.005 +.002	N +.005 +.002
	256, 440	.290	.375
	632	.335	.405
	832	.365	.455
	1024, 1032	.405	.485
	2520, 2528	.510	.615

All dimensions in inches

METRIC	Thread Code	M +0.13 +0.05	N +0.13 +0.05
	M2, M2.5, M3	7.37	9.52
	M3.5	8.51	10.29
	M4	9.28	11.56
	M5	10.29	12.32
	M6	12.96	15.62

All dimensions in millimeters

PERFORMANCE¹ SERIES TYPES NASS, NAST, NALSS and NALST

All dimensions in inches

INCH	Thread Code	Retainer Shank Length	Sheet Material								
			2024-T3 Aluminum			5052-H34 Aluminum			Cold-Rolled Steel		
			Installation (lbs)	Retainer Push-out (lbs)	Retainer Torque-out (in-lbs)	Installation (lbs)	Retainer Push-out (lbs)	Retainer Torque-out (in-lbs)	Installation (lbs)	Retainer Push-out (lbs)	Retainer Torque-out (in-lbs)
			256 440	.038	3000	220	65	1500	215	65	3000
	.054	225	150	2000		225	80	150			
632	.038	3000	235	110	2000	240	140	3000	300	150	
	.054		275	150		250	150			175	
832	.038	3000	240	110	2000	250	140	3000	300	150	
	.054		300	150		265	150		400	200	
1024 1032	.038	3500	300	150	2000	300	150	3500	400	150	
	.054			200		350	175		450	200	
2520 2528	.054	5000	300	325	3000	400	325	5000	500	325	

NA/NAL Self-Clinching Floating Nuts

PERFORMANCE (CONTINUED)¹
SERIES TYPES NASS, NAST, NALSS and NALST

All dimensions in millimeters

METRIC	Thread Code	Retainer Shank Length	Sheet Material								
			2024-T3 Aluminum			5052-H34 Aluminum			Cold-Rolled Steel		
			Installation (kN)	Retainer Push-out (N)	Retainer Torque-out (N-m)	Installation (kN)	Retainer Push-out (N)	Retainer Torque-out (N-m)	Installation (kN)	Retainer Push-out (N)	Retainer Torque-out (N-m)
M2, M2.5 M3	0.97	13.3	978	7.3	6.7	956	7.3	13.3	1334	9.6	
	1.38	13.3	1000	16.9	8.9	1000	9.0	13.3	1334	16.9	
M3.5	0.97	13.3	1045	12.4	8.9	1067	15.8	13.3	1334	16.9	
	1.38	13.3	1223	16.9	8.9	1112	16.9	13.3	1334	19.7	
M4	0.97	13.3	1067	12.4	8.9	1112	15.8	13.3	1334	16.9	
	1.38	15.6	1334	16.9	8.9	1178	16.9	13.3	1779	22.6	
M5	0.97	15.6	1334	16.9	8.9	1334	16.9	15.6	1779	16.9	
	1.38	16.6	1334	22.6	8.9	1556	19.7	15.6	2001	22.6	
M6	1.38	22.2	1334	36.7	13.3	1779	36.7	22.2	2224	36.7	

PERFORMANCE¹
TYPES NAS4 AND NALS4

All dimensions in inches

INCH	Thread Code	Sheet Material		
		300-Series Stainless Steel		
		Installation (lbs)	Retainer Push-out (lbs)	Retainer Torque-out (in-lbs)
256, 440	9000	200	85	
632	10000	200	85	
832	12000	200	85	
1024, 1032	13000	250	125	

(1) Performance data represents reference averages based on commonly reported industry values when all installation specifications and procedures are followed. Variations such as sheet material type, hardness and thickness; hole diameter; method of hole manufacture; size and location of hole burr if any; and amount of installation load will affect the data. PENCOM highly recommends testing in each application to determine actual loads.

All dimensions in millimeters

METRIC	Thread Code	Sheet Material		
		300-Series Stainless Steel		
		Installation (kN)	Retainer Push-out (N)	Retainer Torque-out (N-m)
M2, M2.5, M3	40	890	9.6	
M3.5	45	890	9.6	
M4	53	890	9.6	
M5	57	1100	14.1	

(1) Performance data represents reference averages based on commonly reported industry values when all installation specifications and procedures are followed. Variations such as sheet material type, hardness and thickness; hole diameter; method of hole manufacture; size and location of hole burr if any; and amount of installation load will affect the data. PENCOM highly recommends testing in each application to determine actual loads.